

SUNTREE TECHNOLOGIES MODEL NUMBER: NSBB-5-10-84

FLOW & BY-PASS SPECIFICATIONS FOR BIOMASS SEPARATING SCREEN SYSTEM, SEDIMENT COLLECTION CHAMBERS, AND SKIMMER SPECIFICATIONS

1. Pipe inflow area (Drawn as 24" RCP) — 3.14 sq.ft.

SCREEN SPECIFICATIONS:

- 2. Open orifice area in screen system — 22.84 sq.ft.
- 3. Open orifice area in screen system with 50% blockage — 11.42 sq.ft.
- 4. Open orifice area in screen system with 75% blockage — 5.71 sq.ft.
- 5. Minimum by-pass through screen system — 5.61 sq.ft. below the top surface of the pipe
- 6. Minimum by-pass around screen system — 4.24 sq.ft. below the top surface of the pipe
- 7. Screen system storage volume — 49.16 cu.ft.

SEDIMENT STORAGE:

- 8. Volume of first sediment chamber — 50 cu.ft.
- 9. Volume of second sediment chamber — 48.75 cu.ft.
- 10. Volume of third sediment chamber — 48.75 cu.ft.
- 11. Total sediment volume — 147.5 cu.ft.

SKIMMER SPECIFICATIONS:

- 12. Flow area under skimmer — 5.83 sq.ft.
- 13. Area of pipe in line with skimmer — 2.52 sq.ft.
- 14. Area between the skimmer and the outflow pipe parallel with the surface of the pipe — 7.02 sq.ft.

RECOMMENDED PIPE SIZES: 12" to 24"

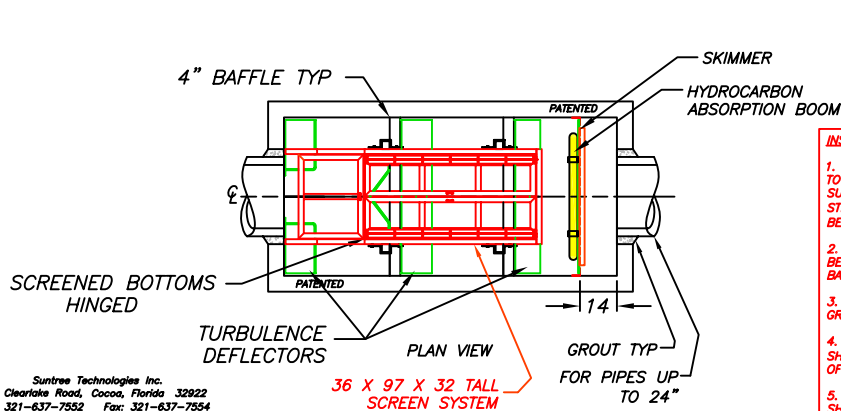

PATENTED
AND PATENTS PENDING

INSTALLATION NOTES:

1. INFLOW AND OUTFLOW PIPES ARE TO BE FLUSH WITH THE INSIDE SURFACE OF THE CONCRETE STRUCTURE. (CAN NOT INTRUDE BEYOND FLUSH)
2. INVERT OF OUTFLOW PIPE SHOULD BE EVEN WITH THE TOP OF THE BAFFLES.
3. BAFFLES SHOULD BE SEALED WITH GROUT.
4. THE BOTTOM OF THE SKIMMER SHOULD BE 6" BELOW THE INVERT OF THE OUTFLOW PIPE.
5. INVERT OF THE INFLOW PIPE SHOULD NOT BE BELOW THE INVERT OF THE OUTFLOW PIPE.

Suntree Technologies Inc.
798 Clearlake Road, Cocoa, Florida 32922
PH: 321-637-7552 Fax: 321-637-7554

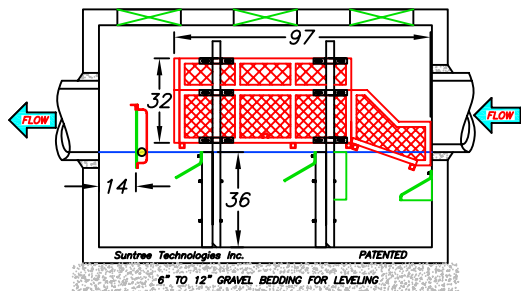

REAR VIEW

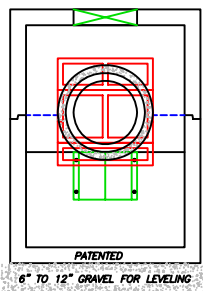

LEFT END VIEW

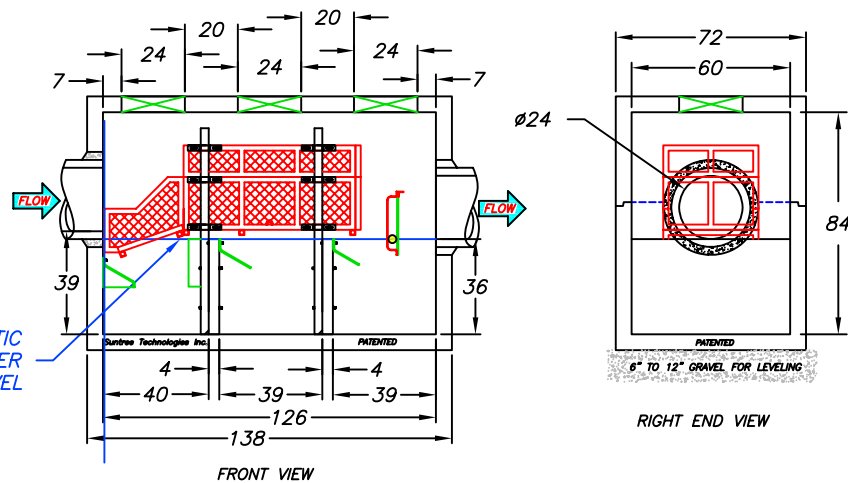

FRONT VIEW

RIGHT END VIEW

Notes:

1. CONCRETE 28 DAY COMPRESSIVE STRENGTH f_c - 5,000 PSI.
2. REINFORCING: ASTM A-615, GRADE 60.
3. SUPPORTS AN H2O LOADING AS INDICATED BY AASHTO.
4. JOINT SEALANT: BUTYL RUBBER SS-S-00210
5. ALL WALL, TOP, AND BOTTOM ARE 6" THICK.
6. INFLOW AND OUTFLOW PIPES ARE TO BE FLUSH WITH THE INSIDE SURFACE OF THE CONCRETE STRUCTURE. (CAN NOT INTRUDE BEYOND FLUSH)
7. HINGED LIDS FOR THE SCREEN SYSTEM ARE AVAILABLE UPON REQUEST.
8. BAFFLES WILL BE SEALED WITH GROUT TO FORM THREE WATER TIGHT CHAMBERS.

TREATMENT DESIGN FLOW
15 cfs

PEAK DESIGN FLOW
30 cfs

SUNTREE TECHNOLOGIES, INC. 798 CLEARLAKE RD, SUITE #2 COCOA, FL. 32922		PROJECT:
NUTRIENT SEPARATING BAFFLE BOX MODEL NO. NSBB-5-10-84		DRAWING #: 2-03-06-08-02
DATE: 2/4/08	SCALE: SF = 72	FILE NAME: NSBB-5-10-84
DRAFTER: T.H.H.	UNITS = INCHES	REVISIONS: DATE:
		REVISIONS: DATE: